



USERS MANUAL / GEBRUIKERSHANDLEIDING / BETRIEBSANLEITUNG
MANUEL UTILISATEUR / MANUAL DE UTILIZACION / INSTRUZIONI PER L'USO

ChargeMaster

12/25-3, 24/12-3

FULL AUTOMATIC BATTERY CHARGER



MASTERVOLT
Snijdersbergweg 93,
1105 AN Amsterdam
The Netherlands
Tel.: +31-20-3422100
Fax.: +31-20-6971006
www.mastervolt.com

ENGLISH:	PAGE 1
NEDERLANDS:	PAGINA 21
DEUTSCH:	SEITE 41
FRANÇAIS:	PAGINA 61
CASTELLANO:	PÁGINA 81
ITALIANO:	PÁGINA 101

CONTENTS:

v 1.5 September 2011

1	GENERAL INFORMATION	3
1.1	Use of this manual.....	3
1.2	Validity of this manual	3
1.3	Use of pictograms	3
1.4	Identification label.....	3
1.5	Liability	3
2	IMPORTANT SAFETY INSTRUCTIONS	4
2.1	General	4
2.2	Explosive gases	4
2.3	Warnings regarding the use of batteries.....	5
2.4	Warning regarding life support applications.....	5
2.5	Guarantee specifications	5
3	OPERATION	6
3.1	Features	6
3.2	Display	6
3.3	Setting mode	6
3.4	Failures.....	6
3.5	Three Step charge algorithm.....	6
3.6	Maintenance.....	7
4	INSTALLATION	8
4.1	Unpacking	8
4.2	Environment	8
4.3	Wiring and batteries	8
4.4	Overview connections	9
4.5	Things you need.....	9
4.6	Connections	9
4.7	Commissioning after installation.....	10
4.8	Decommissioning	10
4.9	Storage and transportation	10
5	MASTERBUS	11
5.1	What is MasterBus?	11
5.2	How to set up a MasterBus network.....	11
5.3	MasterBus functions	12
6	TROUBLE SHOOTING	16
6.1	Fault finding table	16
7	TECHNICAL DATA	17
7.1	Specifications	17
7.2	Dimensions.....	18
7.3	Characteristics.....	19
8	ORDERING INFORMATION	20
9	EC DECLARATION OF CONFORMITY	20

1 GENERAL INFORMATION

1.1 USE OF THIS MANUAL

This manual contains important safety and operating instructions for the ChargeMaster to enable its safe and effective operation, maintenance and possible correction of minor malfunctions.

It is therefore obligatory that every person who works on or with the ChargeMaster is completely familiar with the contents of this manual, and that he/she carefully follows its instructions and important safety instructions.

Copyright © 2011 Mastervolt. All rights reserved.

Reproduction, transfer, distribution or storage of part or all of the contents in this document in any form without the prior written permission of Mastervolt is prohibited.

1.2 VALIDITY OF THIS MANUAL

All of the specifications, provisions and instructions contained in this manual apply solely to standard versions of the ChargeMaster delivered by Mastervolt.

This manual is valid for the following model:

Part number	Model
44010250	ChargeMaster 12/25-3
44020120	ChargeMaster 24/12-3

This model is referred to as "ChargeMaster" further in this manual.

1.3 USE OF PICTOGRAMS

Safety instructions and warnings are marked in this manual by the following pictograms:



WARNING

A WARNING refers to possible injury to the user or significant material damage to the charger if the user does not (carefully) follow the procedures.



CAUTION!

Special data, restrictions and rules with regard to preventing damage.



A procedure, circumstance, etc which deserves extra attention.

1.4 IDENTIFICATION LABEL

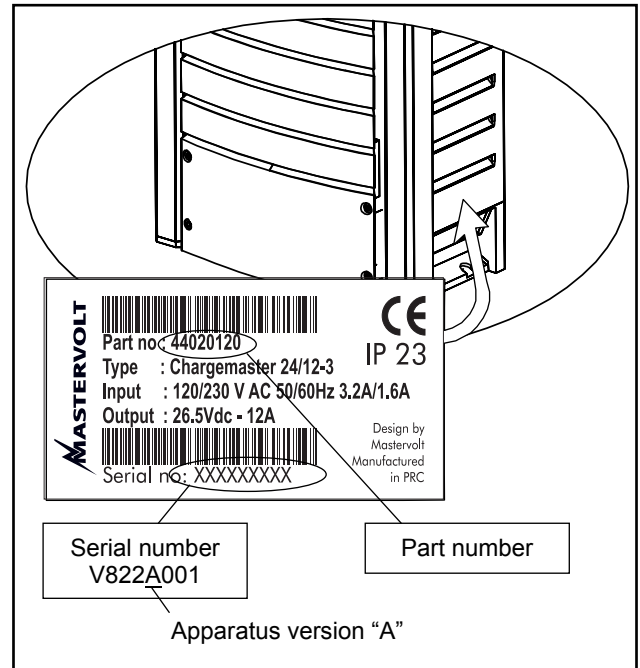

Figure 1: Identification label

The identification label is located at the right-hand side of the ChargeMaster (see figure 1). Important technical information required for service, maintenance & secondary delivery of parts can be derived from the identification label.



CAUTION!

Never remove the identification label.

1.5 LIABILITY

Mastervolt can accept no liability for:

- consequential damage due to use of the ChargeMaster;
- possible errors in the manuals and the results thereof.

2 IMPORTANT SAFETY INSTRUCTIONS

READ AND SAVE THESE INSTRUCTIONS



WARNING

This chapter describes important safety and operating instructions for use of a ChargeMaster in residential, recreational vehicle (RV) and marine applications.

2.1 GENERAL

- 1 Before using the ChargeMaster, read all instructions and cautionary markings on the ChargeMaster, the batteries, and all appropriate sections of the manual.
- 2 To reduce the risk of electric shock – Do not expose ChargeMaster to rain, snow, spray, moisture, excessive pollution and condensing circumstances. To reduce risk of fire hazard, do not cover or obstruct the ventilation openings. Do not install the ChargeMaster in a non-ventilated room, overheating may result.
- 3 Use of an attachment or spare part not recommended or sold by Mastervolt may result in a risk of fire, electric shock, or injury to persons.
- 4 The ChargeMaster is designed to be permanently connected to an AC and DC electrical system. Installation of, and work on the ChargeMaster, should be carried out by a qualified, authorised and trained technician or electrician, consistent with the locally applicable standards and regulations.
- 5 Make sure that all wiring is properly installed and in good electrical condition; and that wire size is large enough for AC ampere rating of the ChargeMaster. Check the wiring on a regular base, at least once a year. Do not use the ChargeMaster when the wiring is undersized or damaged.
- 6 Do not operate ChargeMaster if it has received a sharp blow, been dropped, or otherwise damaged in any way; take it to a qualified serviceman.
- 7 The ChargeMaster may not be opened or disassembled. There are no serviceable parts inside the cabinet. Take it to a qualified, authorized and trained serviceman when service or repair is required. Incorrect reassembly may result in a risk of electric shock or fire.
- 8 To reduce risk of electric shock, disconnect the ChargeMaster from both AC and DC electrical system before attempting any maintenance or cleaning. Turning off controls will not reduce this risk.
- 9 The ChargeMaster must be provided with an equipment-grounding conductor to the AC-input ground terminal. Grounding and all other wiring must comply with local codes and ordinances.
- 10 Short circuiting or reversing polarity will lead to serious damage to batteries, ChargeMaster, wiring as well as accessories. Fuses can not prevent damage caused by reversed polarity and the warranty will be void.
- 11 In case of fire, you must use the fire extinguisher which is appropriate for electrical equipment.
- 12 If applied in a marine application in the United States, external connections to the ChargeMaster shall comply with the United States Coast Guard Electrical Regulations (33CFR183, Sub part I).

2.2 EXPLOSIVE GASES

- 1 **WARNING – RISK OF EXPLOSIVE GASES. WORKING IN VICINITY OF A LEAD-ACID BATTERY IS DANGEROUS. BATTERIES GENERATE EXPLOSIVE GASES DURING NORMAL BATTERY OPERATION. FOR THIS REASON, IT IS OF UTMOST IMPORTANCE THAT EACH TIME BEFORE USING THE CHARGEMASTER, YOU READ THIS MANUAL AND FOLLOW THE INSTRUCTIONS EXACTLY.**
- 2 To reduce risk of battery explosion, follow these instructions and those published by battery manufacturer and manufacturer of any equipment you intend to use in vicinity of the battery. Review cautionary marking on these products.
- 3 The ChargeMaster has been approved ignition protected according to SAE J1171 / ISO 8846, only when installed and in normal operation! **DANGER: To reduce the risk of explosion DURING INSTALLATION OF THE CHARGEMASTER - avoid situations where there is danger of gas or dust explosion and disable all devices in areas in which ignition-protected equipment is required.**

2.3 WARNINGS REGARDING THE USE OF BATTERIES

- 1 Someone should be within range of your voice or close enough to come to your aid when you work near a lead-acid battery.
- 2 Have plenty of fresh water and soap nearby in case battery acid contacts skin, clothing, or eyes.
- 3 Wear complete eye protection and clothing protection. Avoid touching eyes while working near battery.
- 4 If battery acid contacts skin or clothing, wash immediately with soap and water. If acid enters eye, immediately flood eye with running cold water for at least 10 minutes and get medical attention immediately.
- 5 NEVER smoke or allow a spark or flame in vicinity of battery or engine.
- 6 Do not short circuit batteries, as this may result in explosion and fire hazard! Be extra cautious to reduce risk of dropping a metal tool onto battery. It might spark or short-circuit battery or other electrical part that may cause explosion.
- 7 Remove personal metal items such as rings, bracelets, necklaces, and watches when working with a lead-acid battery. A lead-acid battery can produce a short-circuit current high enough to weld a ring or the like to metal, causing a severe burn.
- 8 Only use the ChargeMaster for charging the following battery types: Lead acid, AGM, Spiral, Gel, Deep cycle or Li-ion batteries. Do not use ChargeMaster for charging dry-cell batteries that are commonly used with home appliances. These batteries may burst and cause injury to persons and damage to property.
- 9 NEVER charge a frozen battery.
- 10 Excessive battery discharge and/or high charging voltages can cause serious damage to batteries. Do not exceed the recommended limits of discharge level of your batteries.

- 11 If it is necessary to remove a battery, always remove grounded terminal from battery first. Make sure all accessories are off, so as not to cause an arc.
- 12 Be sure that the area around the battery is well ventilated while the battery is being charged. Refer to the recommendations of the battery manufacturer.
- 13 Batteries are heavy! It may become a projectile if it is involved in an accident! Ensure adequate and secure mounting and always use suitable handling equipment for transportation.

2.4 WARNING REGARDING LIFE SUPPORT APPLICATIONS

Do not use the ChargeMaster for applications in any medical equipment intended for use as a component of any life support system!

2.5 GUARANTEE SPECIFICATIONS

MasterVolt guarantees that this unit has been built according to the legally applicable standards and specifications. If work takes place which is not in accordance with the guidelines, instructions and specifications contained in this user's manual, then damage may occur and/or the unit may not fulfil its specifications. All of these matters may mean that the guarantee becomes invalid.

The guarantee is limited to the costs of repair and/or replacement of the product. Costs for installation, labour or shipping of the defective parts are not covered by this guarantee.

3 OPERATION

3.1 FEATURES

The Mastervolt ChargeMaster is a fully automatic battery charger. This means that under normal circumstances it may stay switched on with the AC power and batteries connected. The ChargeMaster is suitable for charging the following battery types: Lead acid, AGM, Spiral, Gel, Deep cycle batteries and Mastervolt Li-ion batteries (MLI). It has an auto-ranging input facility which makes it feasible to operate on almost any AC power source in the world. It operates on both 230V and 120V without compromising the output current. The three-step Plus charging method guarantees 100% charged batteries. In some cases however, a 2-step charging method is more convenient. This method can be selected in the setting mode. With an

external AC source connected, the ChargeMaster charger also serves the function of an AC to DC converter to supply DC loads which are connected to the batteries.



WARNING

The Li-ion charging voltages on this charger fit the Mastervolt Li-ion (MLI) batteries and do not necessarily fit other Li-ion batteries!

3.2 DISPLAY

The ChargeMaster is equipped with a multicolour LED display. Different LED colours and combinations have different meanings, see below.

Meaning Load bar				Actual state of the 3-step charging method: Float, Absorption and Bulk.	
+ POWER LED <i>green</i>	+ POWER LED <i>blinking red</i>	In <i>Setting mode</i>	Load bar		
Current 100%	Temperature error	Connected to MasterBus			POWER LED (NO BUTTON) Illuminating green = on, red = standby.
Current 75%	Charger failure	MLI Li-ion battery *			
Current 50%	Wrong AC voltage	2-Step charge Off = 3-Step			
Current 25%	Battery voltage high	Wet battery			
Current 5% (Float, Abs, Bulk: On)/ Battery low (Float, Abs, Bulk: Off)	-	Gel/AGM battery			

Figure 2: Display operation of the ChargeMaster
 * function available from firmware version 4.06
 ** display available from revision D

3.3 SETTING MODE

Press Set for 5 seconds to start the setting mode. Done so, you see a blinking LED next to the actual setting. Press Set again to scroll through the settings. Press and hold the button for 5 seconds to save the selected setting or do not touch the button for 60 seconds to leave the settings unchanged. Press Set shortly to see the new setting.

indicates the failure cause. See section 3.2 for explanation.



CAUTION!

We recommend you to check if your system is up to the higher Li-ion (charging) voltages!



CAUTION!

The ChargeMaster is not protected against:

- reversing polarity of the DC-output,
- three phase AC on the AC-input.

3.5 THREE STEP CHARGE ALGORITHM

See figure 3. Battery charging is accomplished in three automatic stages: BULK, ABSORPTION and FLOAT.

The first step of the three step charge system is the BULK phase, in which the output current of the charger is 100%, and the greater part of the capacity of the battery is rapidly charged. The current charges the batteries and gradually the voltage rises to the BULK voltage 14.4V (Li-ion:14.6V) resp. 28.8V (Li-ion: 29.2V) at 25°C / 77°F.

The duration of this phase depends on the ratio of battery to charger capacity, and the battery state of charge.

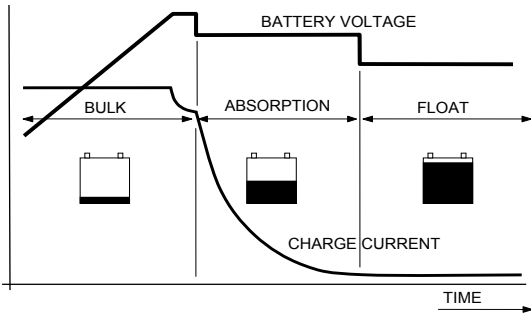

Figure 3: Three step charge system

The bulk phase is followed by the ABSORPTION phase. Absorption charging starts when the voltage on the batteries has reached the BULK voltage, and ends when the battery is completely full. Battery voltage remains constant at 14.25V (Li-ion: 14,6V) / 28.5V (Li-ion: 29.2V) at 25°C / 77°F throughout this stage, and the charge current depends on the degree to which the battery was initially discharged, the battery type, the ambient temperature, and so on. With a wet cell battery this stage lasts approx. 4h, with gel and AGM around 3h. Once the battery is 100% full, the ChargeMaster automatically switches over to the float phase. At FLOAT (for Gel/AGM, Wet batteries) the ChargeMaster switches to a stabilised 13.25V (Li-ion: 13.5V) or 26.5V (Li-ion: 27.0V) at 25°C / 77°F.

Connected DC-loads are powered directly by the charger. If the load is higher than charger capacity, the required additional power comes from the battery, which will be progressively discharged until the charger automatically switches back to the bulk phase. Once consumption decreases, the charger goes back to normal operation of the three-step charge system.

As the ChargeMaster is equipped with a three-step Plus charge system, the batteries can also remain connected to the ChargeMaster during winter. One hour every 12 days the charger automatically switches to absorption to keep the battery running properly and prolong its life span. The three-step Plus charge system is also safe for all the connected equipment.



See also section 7.3 for detailed characteristics of the three step Plus charge system.

3.5.1 Temperature compensated charging

By installing the battery temperature sensor (optional) the charge voltages are automatically adapted for deviating temperatures.

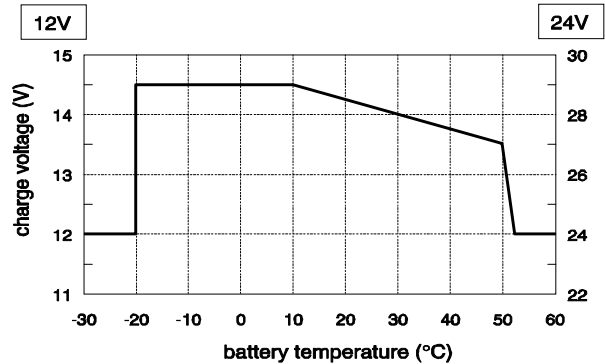

Figure 4: Temperature compensated charging

See figure 4. When the battery temperature is low, the charge voltage increases. On the other hand, when the battery temperature is high, the charge voltage is decreased. Over charge and gassing are prevented this way. This will extend the life of your batteries.

3.5.2 Connection of a second and third battery

The ChargeMaster is equipped with three equal outputs. The total output current is divided over these three outputs. See section 4.6 for connections.

3.6 MAINTENANCE

No specific maintenance to the ChargeMaster is required. Examine your electrical installation on a regular base, at least once a year. Defects such as loose connections, burnt wiring etc. must be corrected immediately.

If necessary, use a soft clean cloth to clean cabinet of the ChargeMaster. Never use any liquids, acids and/or scourers.

4 INSTALLATION

During installation and commissioning of the ChargeMaster, the important safety instructions are applicable at all times. See chapter 2 of this manual.

4.1 UNPACKING

After unpacking, check the contents for possible damage. If in doubt, contact your supplier.

Check from the identification label (see section 1.4) whether the battery voltage is the same as the nominal output voltage of the ChargeMaster (e.g. 24V battery set for a 24V battery charger).

4.2 ENVIRONMENT

Obey the following stipulations during installation:

- The ChargeMaster is designed for indoor use only.
- Operating ambient temperature: -25°C ... 60°C / -13°F ... 140°F (power derating above 25°C / 77 °F to decrease the internal temperature).
- Humidity: 0-95% non condensing.
- Mount the ChargeMaster preferably to a vertical wall, with the connecting cables downwards.
- Make sure that the hot air developed during operation can be discharged. The ChargeMaster must be mounted so that obstruction of the airflow through the ventilation openings will be prevented.
- No objects must be located within a distance of 10 cm / 4 inches around the ChargeMaster.
- Do not locate the ChargeMaster in the same compartment as the batteries.
- Do not install the ChargeMaster straight above the batteries because of possible corrosive sulphur fumes.

4.3 WIRING AND BATTERIES



WARNING!

The wire and fuse sizes stated in this manual are given as example only. Prescribed wire and fuse sizes may be different due to local applicable regulations and standards.

4.3.1 DC wiring

Keep in mind that high current will pass through the DC wiring. Keep the cable lengths shortest possible for highest system efficiency. The recommended minimum cross section of maximum 3m/ 9ft length battery cables for output 1, 2 and 3 is:

Model ChargeMaster	DC cable cross section
12/25-3	6.0 mm ² / 9 AWG
24/12-3	4.0 mm ² / 11 AWG

Use ring terminals on the ends of the wires. The terminals must be crimped with a proper crimping tool. Use the following wire colours for DC wiring colour or at least different colours to make a clear distinction between the positive and negative wire from the battery:

Wire colour	Meaning	Connect to:
Red	Positive	+ (POS)
Black	Negative	- (NEG)

Lay the positive and negative cables next to each other to limit the electro magnetic field around the cables. The negative cable should be connected directly to the negative post of the battery bank or the ground side of a current shunt. Do not use the chassis frame as the negative conductor. Tighten securely. The positive battery cable must be fused and connected to the positive post of the battery bank.

The recommended cable fuses for outputs 1, 2 & 3 and minimum battery capacities are:

Model ChargeMaster	Fuse	Battery Capacity
12/25-3	32A	55Ah
24/12-3	16A	25Ah

4.3.2 AC safety grounding



WARNING!

The ground wire offers protection only if the cabinet of the ChargeMaster is connected to the safety ground. Connect the ground terminal (PE / GND) to the hull or the chassis.



CAUTION!

For safe installation it is necessary to Insert a Residual Current Device (earth leakage switch) in the AC input circuit of the ChargeMaster.

4.4 OVERVIEW CONNECTIONS

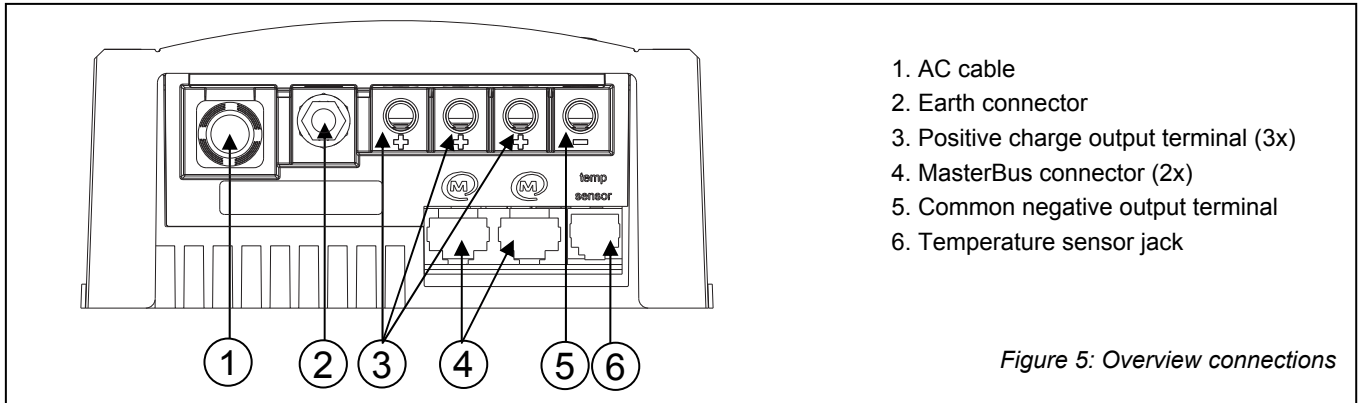

Figure 5: Overview connections

4.5 THINGS YOU NEED

Make sure you have all the parts you need to install the ChargeMaster:	Quantity
ChargeMaster (included)	1
Battery temperature sensor with cable and plug (included)	1
MasterBus terminator	
MasterBus cable	
DC cable to connect the positive DC connection (+) of the ChargeMaster to the positive pole of the DC-distribution; for specifications see section 4.3.1. Cable 1250 mm, 6.0 mm ² / 4.10 ft, 9 AWG.	1
DC-cable to connect the negative DC connection (-) of the ChargeMaster to the negative pole of the DC-distribution; for specifications see section 4.3.1. Cable 1250 mm, 6.0 mm ² / 4.10 ft, 9 AWG.	1
DC-fuse holder with a DC-fuse, to be integrated in the positive DC-cable. For specifications see section 4.3.1.	1
Screws / bolts (Ø 5mm) (with plugs) to mount the cabinet to a surface. Use mounting materials which are suitable to carry the weight of the ChargeMaster.	4
1.5 m AC cable to connect the AC input to an external power source (e.g. a shore connection or a generator set).	1
Batteries. See section 4.3.1 for recommended capacity.	X
Appropriate and reliable cable terminals, cable lugs, battery terminals and cord end terminals	X

See also chapter 8 Ordering Information.

4.6 CONNECTIONS



WARNING

Let installation work be done by a licensed electrician. Before connecting the wiring, make the AC distribution as well as the DC distribution voltage free.



CAUTION!

Short circuiting or reversing polarity may seriously damage the batteries, the ChargeMaster, the cabling and/or the terminal connections. Fuses between the batteries and the ChargeMaster can not prevent damage caused by reversed polarity. Reverse polarity damage is detectable by the service department and not covered by the warranty.



CAUTION!

Too-thin cables and/or loose connections can cause dangerous overheating of the cables and/or terminals. Therefore tighten all connections well, in order to limit transition resistance as far as possible. Use cables of the correct size.



NOTE:

If the battery temperature remains within 15-25°C, connection of the battery temperature sensor is an option.

4.6.1 Connection example

This schematic is to illustrate the general placement of the ChargeMaster in a circuit. It is not meant to provide detailed wiring instructions for any particular electrical installation.

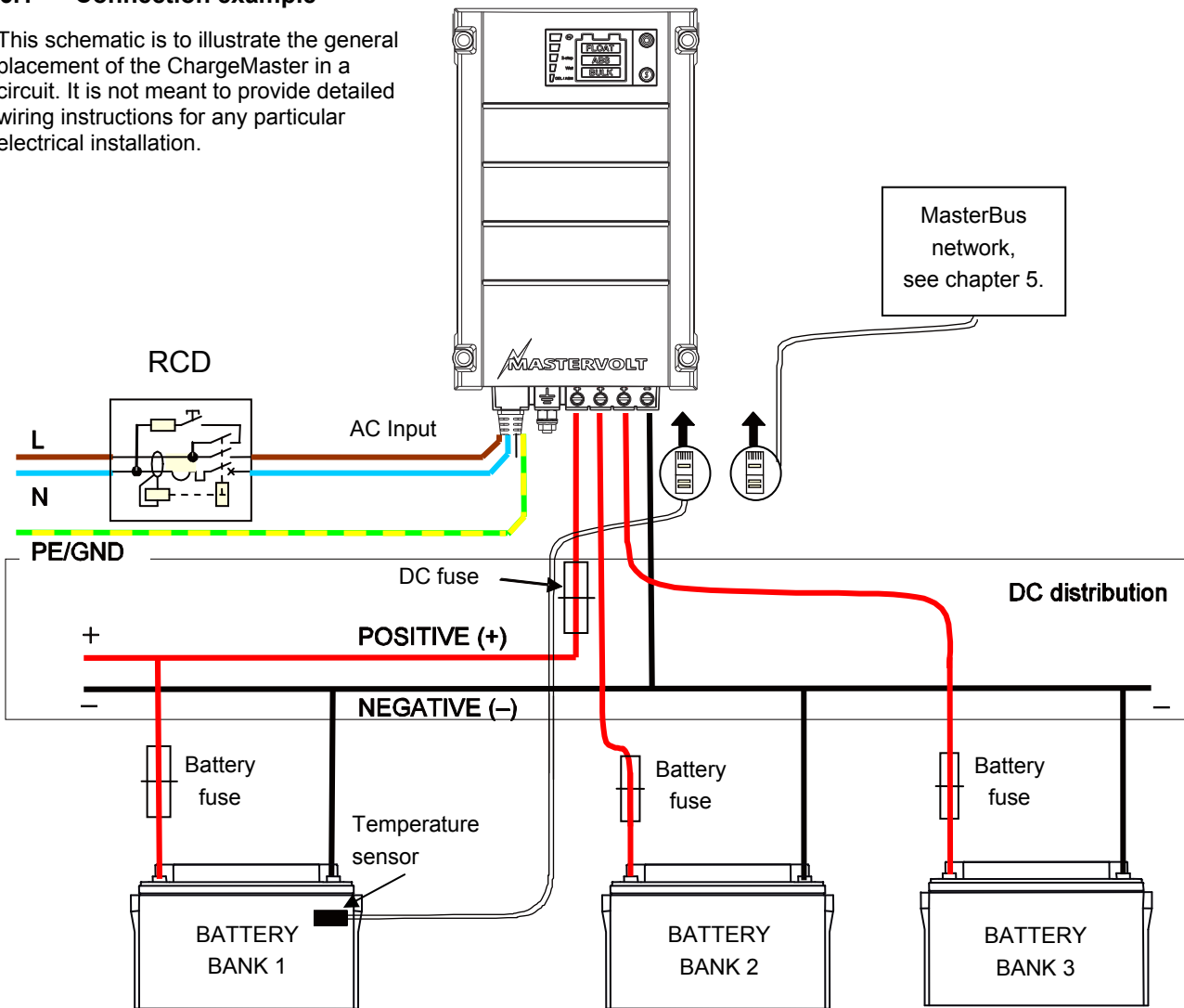

Figure 6: installation example of the ChargeMaster

4.7 COMMISSIONING AFTER INSTALLATION



CAUTION! Check the polarity of all wiring before commissioning: positive connected to positive (red cables), negative connected to negative (black cables).

If all wiring is OK, place the DC-fuse(s) of the DC-distribution to connect the batteries to the ChargeMaster.



WARNING

When placing this fuse, a spark can occur, caused by the capacitors used in the ChargeMaster. This is particularly dangerous in places with insufficient ventilation, due to the gassing of the batteries an explosion can occur. Avoid having flammable materials close by.

Now the ChargeMaster is ready for operation. After switching on the AC power supply the ChargeMaster will initiate the charging process.

4.8 DECOMMISSIONING

To put the ChargeMaster out of operation, follow these instructions in order of succession:

- 1 Switch Off the AC supply for the ChargeMaster.
- 2 Remove the DC-fuse(s) and disconnect the batteries.
- 3 Disconnect all the wiring.

4.9 STORAGE AND TRANSPORTATION

When not installed, store the ChargeMaster in the original packing, in a dry and dust free environment. Always use the original packing for transportation. Contact your local Mastervolt Service Centre for further details if you want to return the apparatus for repair.

5 MASTERBUS

5.1 WHAT IS MASTERBUS?



All devices that are suitable for MasterBus are marked by the MasterBus symbol.

MasterBus is a fully decentralized data network for communication between the different Mastervolt system devices. It is CAN-bus based which has proven itself as a reliable bus-system in automotive applications. MasterBus is used as power management system for all connected devices, such as the inverter, battery charger, generator and many more. This enables communication between the connected devices, for instance to start the generator when the batteries are low.

MasterBus reduces complexity of electrical systems by using UTP patch cables. All system components are simply chained together. Therefore each device is equipped with two MasterBus data ports. As only a few MasterBus cables are needed, installation and material costs are reduced importantly. New devices can be added to the existing network easily. Consequently the MasterBus network is highly flexible for extended system configuration. Mastervolt also offers several interfaces like the Modbus interface, making even non-MasterBus devices suitable to operate in the MasterBus network.

For central monitoring and control of the connected devices Mastervolt offers four different panels, from the small Mastervision compatible 120 x 65mm LCD screen up to the full colour MasterView System panel. All monitoring panels can be used for monitoring, control and configuration of all connected MasterBus equipment.



CAUTION: Never connect a non-MasterBus device to the MasterBus network directly! This will void warranty of all MasterBus devices connected.

5.2 HOW TO SET UP A MASTERBUS NETWORK

Every MasterBus device is equipped with two data ports. When two or more devices are connected via these ports, a local data network called the MasterBus is formed. Keep the following rules in mind:

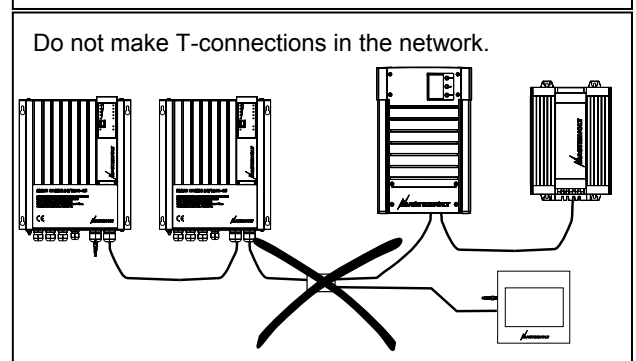
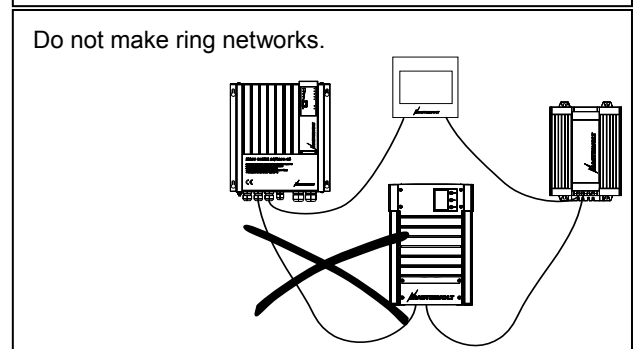
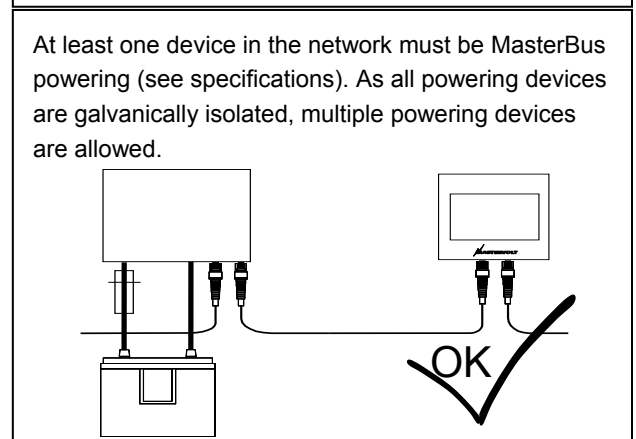
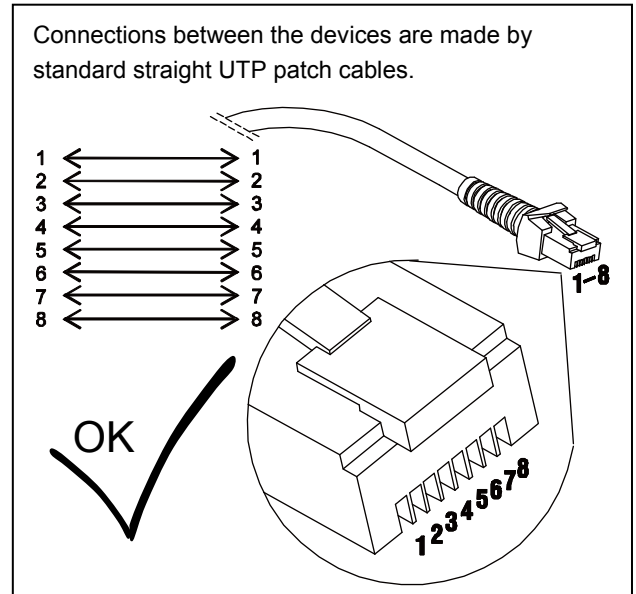
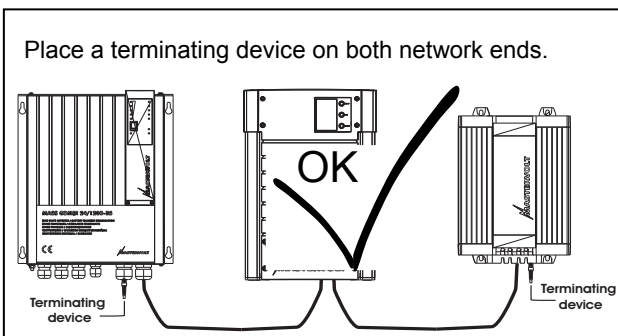

5.3 MASTERBUS FUNCTIONS

Adjustment of the settings of the ChargeMaster can be made via the MasterBus network (by means of a remote control panel or an interface connected to a PC with MasterAdjust software).



CAUTION!

Invalid settings of the ChargeMaster can cause serious damage to your batteries and/or the connected load! Adjustments of settings may be undertaken by authorised personnel only.

5.3.1 Monitoring

Value	Meaning
State	Shows charger state: Charging/ Stand by/ No AC/ - - - (2-step)
Max input power	Option to set the maximum current at the input to prevent generator or shore fuse overload
Charger state	State of charge algorithm: Bulk/ Absorption/ Float
House bank	Voltage of charger output 1*
Charge current	Total charge current*
House bank	Temperature of battery 1
Output 2	Voltage of charger output 2*
Output 3	Voltage of charger output 3*
AC input	AC input voltage
State	Option to switch the ChargeMaster On/ Stand by
<i>System</i>	
Connect to Shunt	A connected MasterShunt can be chosen for feedback on the charged battery.
MasterShunt....	Information on the MasterShunt linked to the ChargeMaster.

5.3.2 Alarms

Value	Meaning	Factory setting	Adjustable range
Battery low	Battery voltage has dropped below setting <i>DC low on</i> , and has not increased above setting <i>DC low off yet</i>	See Configuration/alarms	See Configuration/alarms
Battery high	Battery voltage has increased above setting <i>DC high on</i> , and has not dropped below setting <i>DC high off yet</i>	See Configuration/alarms	See Configuration/alarms
AC low	AC input voltage is too low	90 V*	n/a
AC high	AC input voltage is too high	260 V*	n/a
Frequency low	AC input frequency is too low	40 Hz	n/a
Frequency high	AC input frequency input is too high	67 Hz	n/a
Temperature low	Internal temperature is too low	-20 °C (-4 °F)	n/a
Temperature high	Internal temperature is too high	70 °C (176 °F)	n/a
Temp sense error	Temperature sensor is in failure		
MSH out of range	Values the MasterShunt transmits exceed the limits.		

* See section 7.3, figure 14 for characteristics

5.3.3 History

This menu shows the total historical readings (read only).

Value	Meaning
<i>Charger</i>	
Charge cycles	Number of completed cycles
Charge cycles	Number of aborted charge cycles
Ah charged	Total Ampere hours charged
Total run time	Total run time in charger mode
Highest AC volt	Highest AC input voltage
Temperature	Number of temperature shutdowns
DC Low	Number of low DC voltage shutdowns
DC High	Number of high DC voltage shutdowns
AC Low	Number of low AC voltage shutdowns
AC High	Number of high AC voltage shutdowns
<i>House bank</i>	
Lowest voltage	Lowest detected DC voltage output 1
Highest voltage	Highest detected DC voltage output 1
<i>Output 2</i>	
Lowest voltage	Lowest detected DC voltage output 2
Highest voltage	Highest detected DC voltage output 2
<i>Output 3</i>	
Lowest voltage	Lowest detected DC voltage output 3

Value	Meaning
Highest voltage	Highest detected DC voltage output 3
System	
Last MPC from:	The latest Maximum Power Control-command the ChargeMaster received as event target, see section 5.3.6. This value shows what device controlled/ reduced the ChargeMaster.

5.3.4 Configuration

Below parameters can be changed via the MasterBus network by means of a remote control panel or by means

of an interface connected to a PC with MasterAdjust software. See applicable user's manuals for details.

Value	Meaning	Factory setting	Adjustable. range
General			
Language	Language displayed on MasterBus monitoring device	English	See specifications
Product name	Name of this device. This name will be recognized by all devices connected to the MasterBus.	CHG CM+type*	0-12 chars
Output 1	Name of output 1 in the MasterBus network	House bank	12 characters max
Output 2	Name of output 2 in the MasterBus network	Output 2	12 characters max
Output 3	Name of output 3 in the MasterBus network	Output 3	12 characters max
Factory settings	Button to reset the ChargeMaster to factory settings		
Charge current			
AC load	Select the method to reduce the AC input power	Auto	Auto, MPC, manual
Maximum current	Set the maximum charging current allowed	Model depend.	Model dependent
System			
System behaviour	Set the use mode. The ChargeMaster can be synchronized with a MasterShunt (if <i>Connect to MasterShunt</i> is selected).	Stand alone	Stand alone, synchronized
MasterShunt	Select the MasterShunt to provide battery information.		
Bulk			
Bulk voltage	Bulk voltage Lead acid battery Li-ion battery	14.40/28.80V 14.60/29.20V	0-15.50/0-31.00V
Max. bulk timer	Maximum bulk timer	480min	0-24h
Min bulk timer	Minimum bulk timer	120sec	0-240sec
Start max bulk timer	Startvoltage maximum bulk timer	13.25/ 26.50V	(Read only)
Absorption			
Abs. voltage	Absorption voltage Lead acid battery Li-ion battery	14.25/28.50V 14.60/29.20V	0-15.50/0-31.00V
Max absorption	Maximum absorption timer	240min	0-24h
Min absorption	Minimum absorption timer Lead acid [Li-ion]	15min [120min]	0-240min
Return amps	Return amps (% of maximum charge current)	6%	0-50%
Return amps tim	Return amps timer Lead acid [Li-ion]	30sec [240sec]	(Read only)
Float settings			
Float voltage	Float voltage Lead acid battery AGM, Gel battery Li-ion battery	13.25/26.50V 13.80/27.60V 13.50/27.00V	0-15.50/0-31.00V
Forced float vo.	Forced float voltage (Constant voltage charging) Li-ion battery	13.25/26.50V 13.50/27.00V	0-15.50/0-31.00V
Return to bulk	Return to bulk voltage Lead acid battery Li-ion battery	12.80/25.60V 13.25/26.50V	0-15.50/0-31.00V
Return to bulk	Return to bulk time delay for Lead acid [Li-ion] battery	30sec [240sec]	1-240sec
Alarms			
DC high on	Alarm DC High on	16.00/32.00V	0-16.00/0-32.00V
DC high off	Alarm DC High off	15.00/30.00V	0-16.00/0-32.00V
DC low on	Alarm DC low on	10.00/20.00V	0-16.00/0-32.00V
DC low off	Alarm DC low off	11.00/22.00V	0-16.00/0-32.00V
Alarm delay	Alarm delay time	30sec	0-240sec
Traction			
Traction Bulk	Traction bulk voltage	+300/+600mV	0-1200mV
Traction Absorpt	Traction absorption voltage	+300/+600mV	0-1200mV
Traction Absorpt	Traction absorption timer	8 hrs	(Read only)

Value	Meaning	Factory setting	Adjustable. range
<i>Hardware settings</i>			
Battery type	Setting for AGM/Gel batteries.	Wet	Wet, AGM/ Gel
Charge algorithm	12V/24V power supply allowed. Off=no, On=yes	Off	Off, On
AC Off, MasterBus On	Option to keep MasterBus powered when the AC supply is disabled and the battery is connected.	Auto	(Read only)
<i>Events</i>			
Event x source	Event by the ChargeMaster that should result in an action by one of the other devices on the MasterBus network. Nine events are available: x can be 1-9.	Disabled	See section 5.3.5 Event source list.
Event x target	Select a connected MasterBus device that should take action due to a ChargeMaster event.	Select...	Selectable targets are system dependent.
Event x command	Action to be taken by the target device.	Select...	See command list in manual of the selected device. ChargeMaster section 5.3.6.
Event x data	Data is linked to the command. See also figure 12.	Off	Off, On, Copy, Copy Invert, Toggle.
Event x+1	The next event appears after enabling Event x.	Disabled	See Event x.

* Depending on model: CM12/25, CM24/12

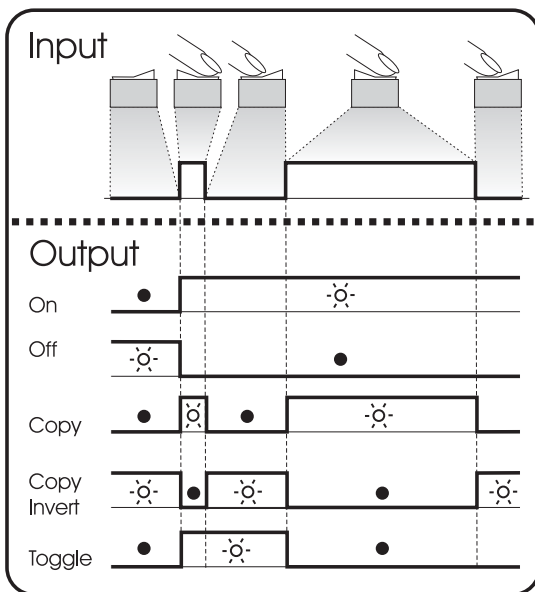

Figure 12: Event data

Figure 12 shows the meaning of the event data. **Input** is a pulse followed by a longer signal (1/0). **On** changes the status to On at the first signal. **Off** changes the status to Off at the first signal. **Copy** lets the status follow the input.

Copy Invert lets the status follow the opposite of the input. **Toggle** changes the status at the first signal and back at the second signal. It is often used in combination with a pulse switch.

5.3.5 ChargeMaster event source list (ChargeMaster as event source)

On	ChargeMaster state is On
Bulk	State of charge is Bulk
Abs	State of charge is Absorption
Float	State of charge is Float
Failure	Charger failure MasterBus alarm
CSI	Charger Status Interface MasterBus alarm to sound a horn at charger failure
Fan	MasterBus signal for an external fan to start (at 50% load / 50°C)
Led 1	Bottom yellow LED of the MasterView Read Out illuminates (see manual MasterView Read Out)
Led 2	2nd yellow LED from bottom of the MasterView Read Out illuminates (see manual MasterView Read Out)
Led 3	3rd yellow LED from bottom of the MasterView Read Out illuminates (see manual MasterView Read Out)
Led 4	4th yellow LED from bottom of the MasterView Read Out illuminates (see manual MasterView Read Out)
Led 5	Top yellow LED of the MasterView Read Out illuminates (see manual MasterView Read Out)

5.3.6 ChargeMaster event target list (ChargeMaster as event target)

Mpc reduce power	Command to reduce AC current at a 5%/sec rate
Mpc stop	Command to reduce AC current fast
Bulk	Command to start the Bulk state of charge
Abs	Command to start the Absorption state of charge
Float	Command to start the Float state of charge
State	Command to switch on the ChargeMaster

6 TROUBLE SHOOTING

If you cannot solve a problem with the aid of this chapter, contact your local Mastervolt Service Centre. See www.mastervolt.com. Make sure you have the following information present if you have to contact your local Mastervolt Service Center to solve a problem:

Article and serial number: see section 1.4.

Firmware version: doubleclick on ChargeMaster icon in MasterView System software Configuration.

6.1 FAULT FINDING TABLE

Malfunction	Possible cause	What to do
No output voltage and/or current	No AC-input	Check AC wiring.
	AC-input voltage too low (< 90VAC)	Check input voltage, check generator.
	AC input frequency out of range	Check input voltage, check generator.
Output voltage too low, charger supplies maximum current	Load that is connected to the batteries is larger than charger can supply.	Reduce load taken from the batteries.
	Batteries not 100% charged	Measure battery voltage. After some time this will be higher.
Charge current too low	Batteries almost fully charged	Nothing, this is normal when the battery is almost fully charged.
	High ambient temperature	Nothing; if ambient temperature is more than the setting limit the charge current is automatically reduced.
	Low AC input voltage. At lower AC input voltages the charge current is reduced.	Check AC-input voltage.
Batteries not fully charged	Charge current too low	See "Charge current too low" in this table.
	Current to load is too high	Reduce load taken from the batteries.
	Charge time too short	Use a battery charger with higher capacity.
	Battery temperature too low	Use the optional battery temperature sensor.
	Defective or old battery	Check battery and replace if necessary.
Batteries are discharged too fast	Battery capacity reduced due to wastage or sulphation, stagnation	Charge and recharge a few times, this might help. Check battery and replace if necessary.
Batteries are too warm, gassing	Defective battery (short circuit in cell)	Check battery and replace if necessary.
	Battery temperature too high	Use the battery temperature sensor.
	Charge voltage too high	Check settings (see section 5.3.4).

7 TECHNICAL DATA

7.1 SPECIFICATIONS

Specifications are subject to change without prior notice.

Model	12/25-3	24/12-3
Article no.	44010250	44020120
Nominal input voltage:	120/230V	120/230V
Nominal input frequency:	50/60Hz	50/60Hz
Full load consumption:	450VA	435VA
Efficiency at full load (230V AC):	≥80% @ 230V input	≥80% @ 230V input
Nominal output voltage:	12V	24V
Total maximum charge current:	25A at 13.25V / 13.5V	12A at 26.5V / 27.0V
Number of battery outputs:	3	3
Output voltage range adjustable	0 to 15.5V DC	0 to 31V DC
Charge characteristic:	IUoUo, automatic, three step	IUoUo, automatic, three step
Charge voltage Bulk:	14.4V (MLI: 14.6V)	28.8 (MLI: 29.2V)
Charge voltage Absorption:	14.25V (MLI: 14.6V)	28.5 (MLI: 29.2V)
Charge voltage Float:	13.25V (AGM, GEL: 13.8V, MLI: 13.5V)	26.5 (AGM, GEL: 27.6V, MLI: 27.0V)
Max. absorption and max. bulk timer:	8 hours (start max. bulk timer at 13.25V)	8 hours (start max. bulk timer at 26.5V)
Minimum absorption time:	15 min.	15 min.
Battery type settings:	Wet battery/ gel/ / AGM / spiral / Li-ion (adjustable by means of display or MasterBus)	Wet battery/ gel/ AGM / spiral / Li-ion (adjustable by means of display or MasterBus)
Dimensions in mm/ inch:	See section 7.2	See section 7.2
Weight:	< 1.8 Kg/ 4.0Lbs including AC cable	< 1.8 Kg/ 4.0Lbs including AC cable
Recommended battery capacity:	55 Ah	25 Ah
Power factor regulations	≤ 0.99	≤ 0.99
Temperature compensation	Yes	Yes
Voltage compensation	Yes, automatic compensation with battery temperature sensor.	Yes, automatic compensation with battery temperature sensor.
DC consumption	<2mA	<2mA
Temperature range	-25°C ... 60°C / -13°F ... 140°F, power derating 2.85%/°C (5.13%/°F) above 25°C / 77 °F to decrease the internal temperature. From -25°C to 0°C / -13°F to 32°F, 90% derating.	-25°C ... 60°C / -13°F ... 140°F (power derating 2.85%/°C (5.13%/°F) above 25°C / 77 °F to decrease the internal temperature). From -25°C to 0°C / -13°F to 32°F, 90% derating.
Cooling	Vario fan and natural cooling to ensure optimized cooling.	Vario fan and natural cooling to ensure optimized cooling.
Sound level	<50dBA / 1m	<50dBA / 1m
Protection degree	IP23	IP23
Approvals	Fully CE and E-marking according to automotive directive 95/54/EG.	Fully CE and E-marking according to automotive directive 95/54/EG.
Communication	Full MasterBus	Full MasterBus

7.2 DIMENSIONS

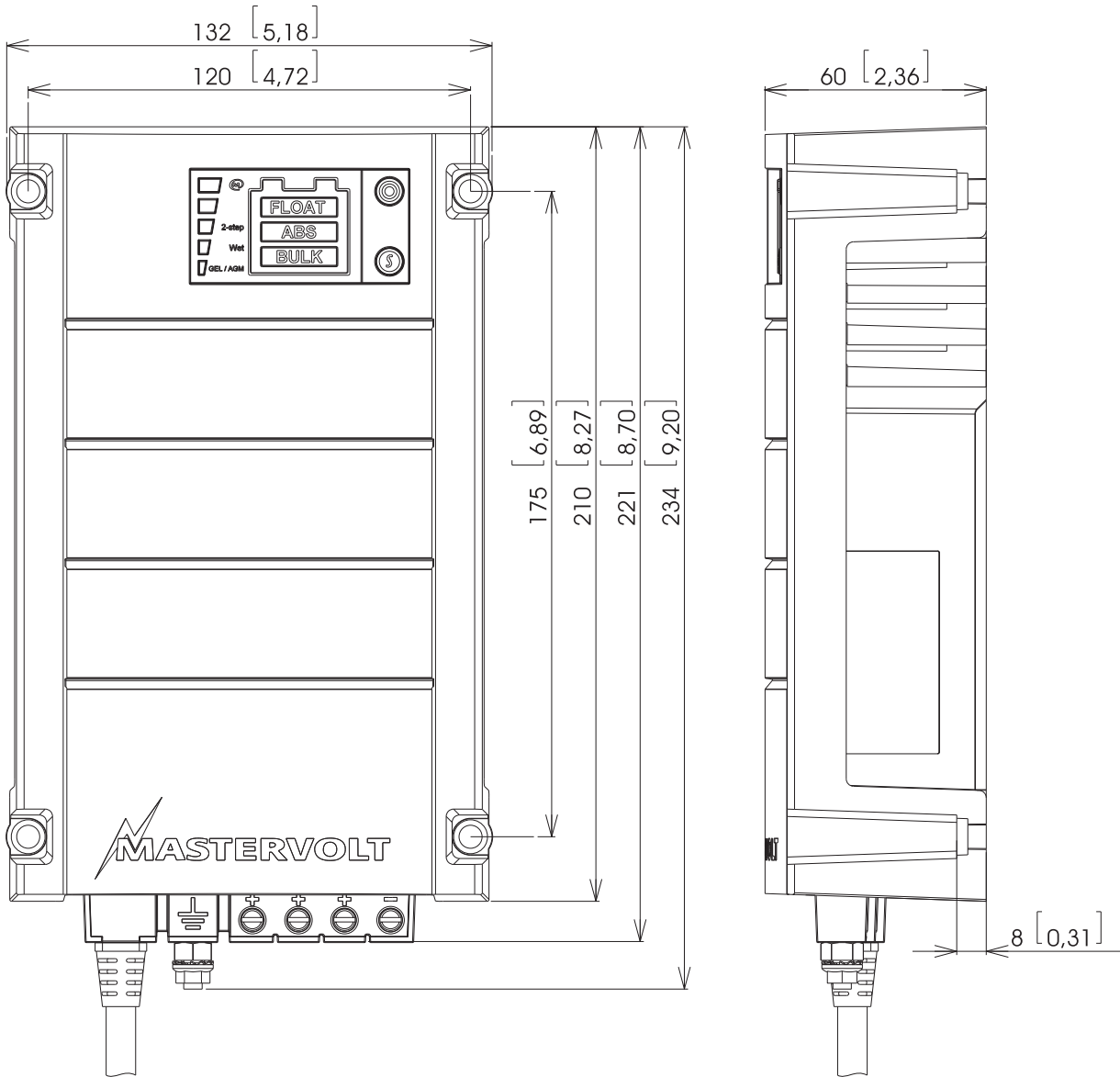
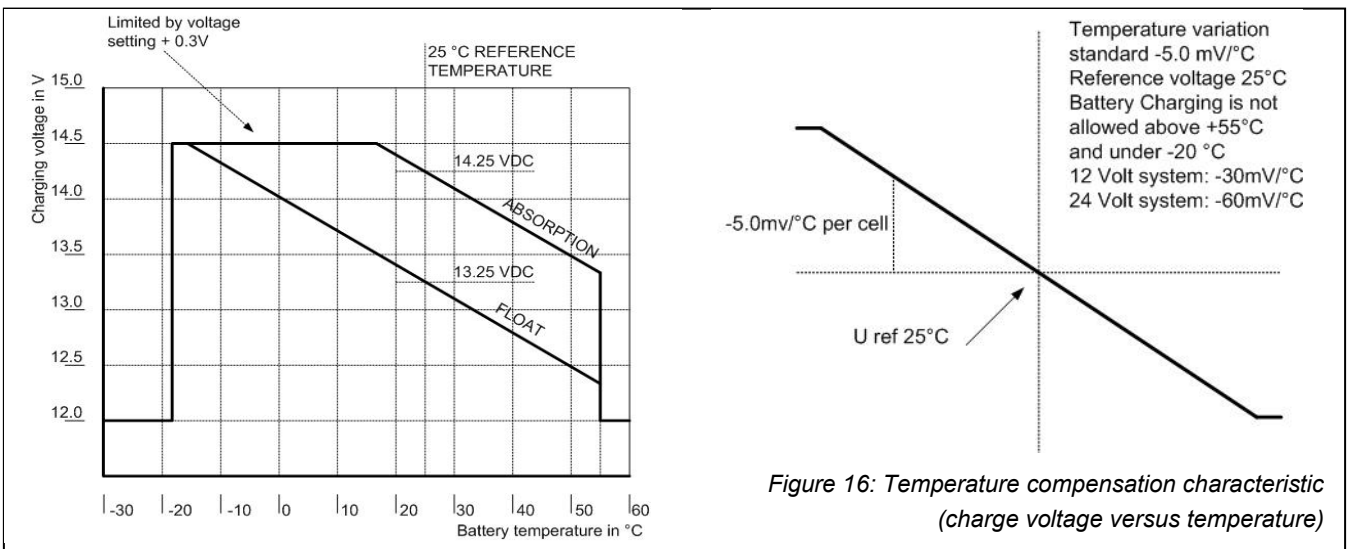
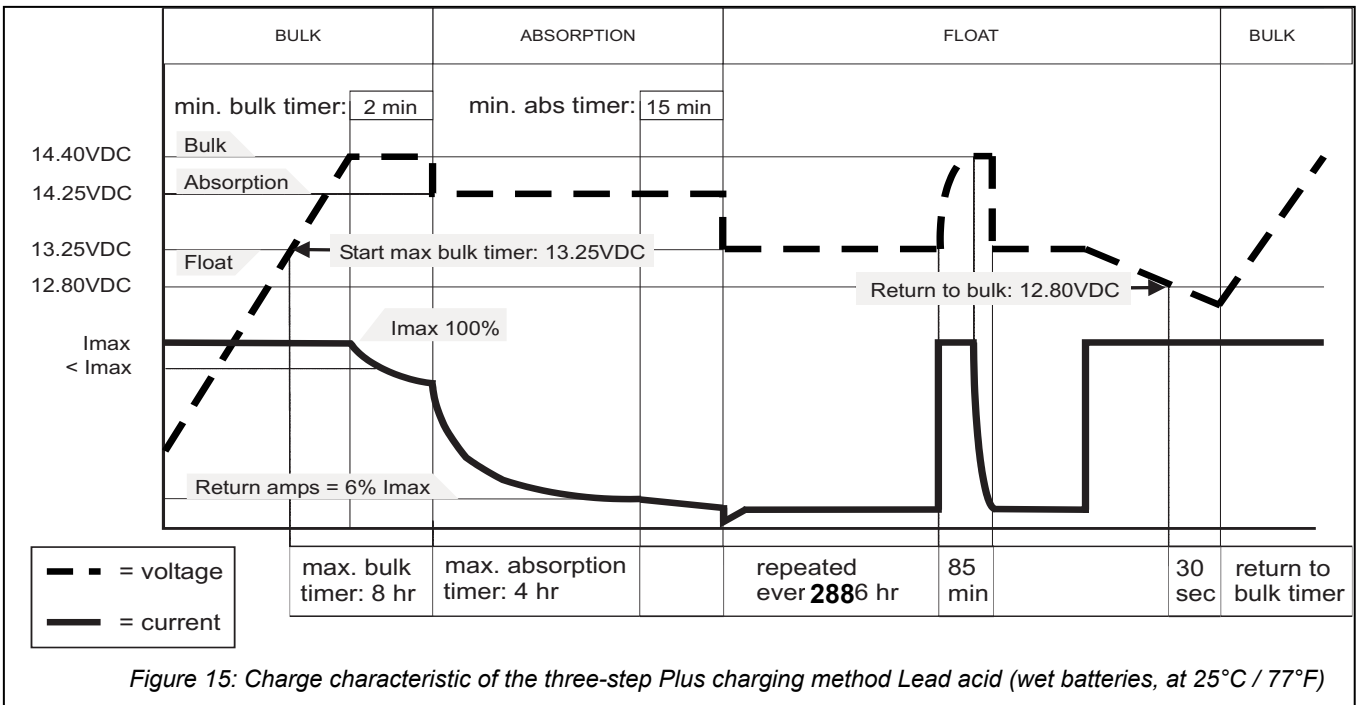
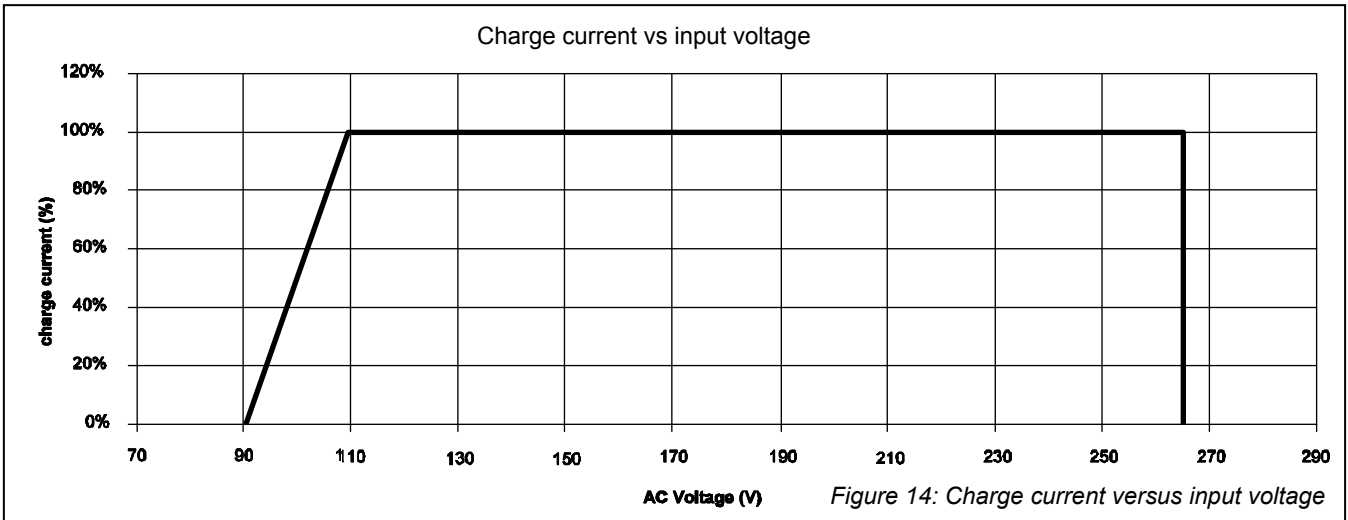

Figure 13: Dimensions in mm [inch]

7.3 CHARACTERISTICS



8 ORDERING INFORMATION

Part number	Description
6384001600	Industrial DC fuse 16A DIN 00
6384003200	Industrial DC fuse 32A DIN 00
6381001000	Fuse base DIN 00 (max. 160A)
79009006	Battery switch 250A with knob
79009005	Battery switch 250A with key
41500500	Battery temperature sensor, incl. 6 metres / 19 ft cable
41500800	Battery temperature sensor, incl. 15 metres / 49 ft cable
77040000	MasterBus Terminator

Mastervolt offers a wide range of products for your electrical installation, AGM, Gel and Li-ion batteries, shore power connections, DC distribution kits and many more.

9 EC DECLARATION OF CONFORMITY

Manufacturer Mastervolt
 Address Snijdersbergweg 93
 1105 AN Amsterdam
 The Netherlands



Herewith declares that product:

44010250 ChargeMaster 12/25-3
 44020120 ChargeMaster 24/12-3

Is in conformity with the provision of the EC, EMC directive 2004/108/EC.

The following harmonized standards have been applied: EN 55014, EN 55022,

EN 61000-3-2, EN 61000-3-3, EN 61000-3-11, EN 61000-6-2, EN 60950, EN60335-1, EN60335-2-29, EN 68-2-6

Low Voltage Directive: 2006/95/EC

Amsterdam,

P.F. Kenninck,
 General Manager MASTERVOLT



Snijdersbergweg 93, 1105 AN Amsterdam, The Netherlands

Tel : + 31-20-3422100

Fax : + 31-20-6971006

Email : info@mastervolt.com